

REFINING ACCESSORIES



DESIGN FEATURES:

- Cast iron pouring molds are available in various capacities.
- Cascading mold stands custom made to fit existing melting furnace installations, available in stationary or portable designs.
- Silicon carbide fused lip crucibles for use in all melting furnaces, ranging in size from a number 50 to a number 600 tilting furnace.
- Custom fabricated carts for transporting cast iron slag pots, multi level tray carts equipped with swivel casters for handling pouring molds.
- Aluminized hard hat hoods with high temperature lexan windows.
- Aluminized garments including hand gauntlet, coats, pants, boot covers, fire retardant nomex® lined with velcro® fasteners.
- Aluminized curtains cut to order, used for isolating designated “hot spot” areas within the melting furnace operation.
- Material handling tools, cast iron ladles and tongs designed for a variety of applications.



INDUSTRY USES:

Denver Mineral Engineers, Inc. offers a variety of tested and proven products for use in handling and containment of precious metal concentrates including:

- Cast iron pouring molds
- Aluminized garments
- Silicon carbide crucibles
- Specialized hand tools



DENVER
MINERAL ENGINEERS, INC.
10,001 S. Highway 121, RR#1
Littleton, CO 80125

Telephone: (303) 932-6280
Fax: (303) 932-6205
E-Mail: sales@denvermineral.com
Web Page: <http://www.denvermineral.com>

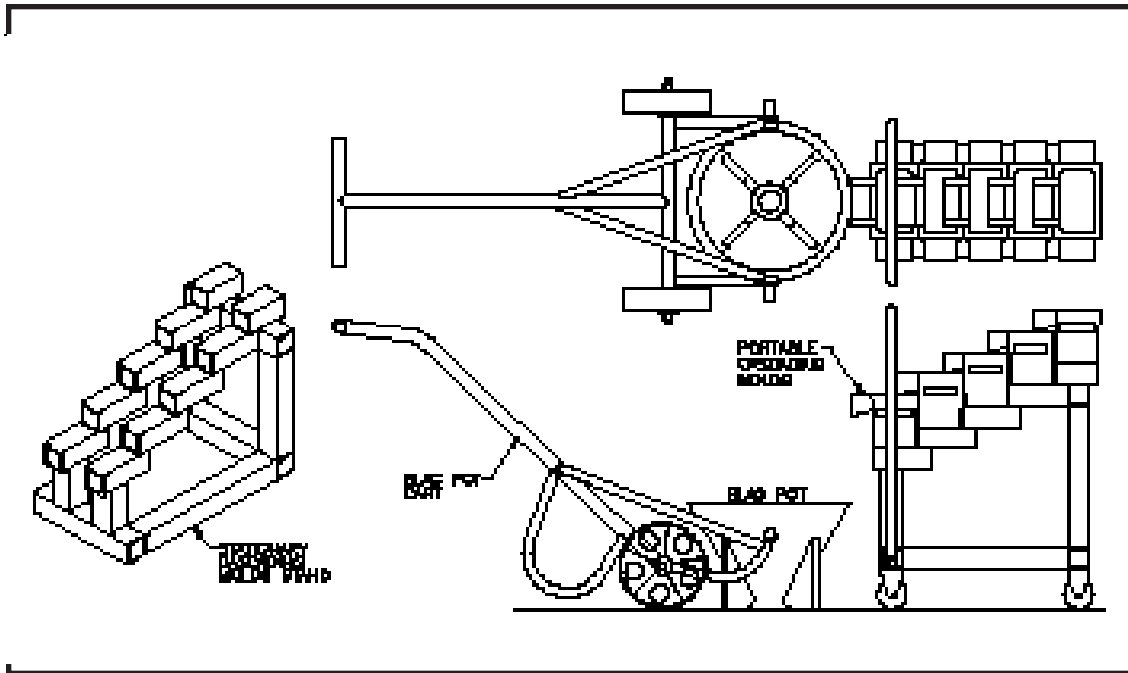

SPECIFICATIONS

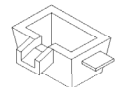

FUSED LIP CRUCIBLES

CAST IRON INGOT MOLDS

		Height	CAPACITY cu.ft.	WEIGHT lb.	MODEL	Length Width Depth	CAPACITY Gold troy oz.	WEIGHT
#30	Silicon carbide (not fused lip)	11 5/8"x8 9/16"x6 7/16"		23	DME#5	7 1/4"x4 1/4"x3 7/8"	45 cu.in./500 oz.	20 lb.
#50	Silicon carbide	13 13/16"x10 1/4"x8 1/4"	0.35	55	DME#10	14 5/8"x5"x4 3/8"	75 cu.in./1000 oz.	32 lb.
#80	Silicon carbide	15 13/16"x11 9/16"x9 7/16"	0.52	75	DME#11	16 3/4"x9 1/4"x6"	115 cu.in./1100 oz.	35 lb.
#125	Silicon carbide	17 1/2"x12 7/8"x10 3/8"	0.69	100	DME#17	16 3/4"x9"x7 1/2"	190 cu.in./1700 oz.	40 lb.
#225	Silicon carbide	20 7/8"x15 7/16"x12 1/2"	1.35	145	CONICAL SLAG POT			
#300	Silicon carbide	22 3/4"x16 3/4"x13 3/8"	1.75	165	MODEL	Diameter Depth	CAPACITY Gold troy oz.	WEIGHT
#400	Silicon carbide	24 1/2"x18 1/2"x14 1/2"	2.13	185	DME#55	8"x14"	100.5 cu.in.	37 lb.
#500	Silicon carbide	22 1/2"x23 3/8"x14 1/2"	2.90	265	DME#75	19"x14"	1323 cu.in.	85 lb.
#600	Silicon carbide	27 3/8"x23 3/8"x14 1/2"	3.42	305				